



## **Acousto-Optic Deflector Driver**

**Including: Basic Deflector Alignment**

### **Instruction Manual**

RFA341 Series

Models -

RFA341 : 10V Tuning Input, 10V Analog Modulation Input

#### **Options:**

-BR, brass water cooled heatsink,  
(recommended for low corrosion copper cased AO devices)



## 1. GENERAL

The RFA341 combined Driver and Power Amplifier, Figure 1, is a modular, swept-frequency RF power source specifically designed to operate with Isomet acousto-optic deflectors such as the 1209 series. The driver accepts a tuning voltage between approximately +0 volts and +10 volts and provides an RF output to the acousto-optic deflector at the tuned frequency. The driver also accepts an analogue amplitude modulation signal. This provides for intensity control and/or fast amplitude modulation across the scan range.

A summary of the driver specification is shown in the following table:

<u>Model</u>	<u>Output Frequency</u>	<u>Output Power</u>
RFA341	30 - 50MHz	> 65.0 Watt

Figure 2 is a block diagram of the Driver. The output frequency of the driver is controlled by a hybridized varactor oscillator circuit. The capacitance of the internal varactor is a function of the applied tuning voltage. The output frequency is proportional to the input tuning voltage with a scale factor of approximately 2.0 MHz/volt. The start frequency corresponds to a tuning voltage of 0.0 volts and is pre-set at 30MHz. A table of output frequency versus input tuning voltage is supplied with each driver and is pseudo-linear. The frequency linearity is typically  $\pm 1.5\%$ , and frequency stability is typically  $\pm 0.25\%$ .

A frequency monitor (**Fmon**) output provides a low level (approx. 300mVpp) output signal at the tuned operating frequency. This can be used for measurement or feedback purposes.

A high-frequency, diode ring modulator is used to amplitude-modulate the RF carrier. A 10 volts swing on the modulation input (positive with respect to ground) will result in 100% depth of modulation. Figure 3 shows the modulation control.

**The input level must not exceed 15 volts**

The amplitude-modulated RF is subsequently applied to the output power amplifier stage. This amplifier is designed to operate at full rated power into a  $50\Omega$  load with 100% duty cycle.

Typical waveforms are given in Figure 6

## 2. FRONT PANEL CONTROLS

The multi-turn variable potentiometer situated to the right of the front panel LED's allows adjustment of start frequency (FOS). This is the frequency output at 0V tuning voltage input.

For optimum scan flatness, the operating frequency range may require a setting +/- 10% about the nominal centre. The limits of this adjustment cover the full tuning range. This allows the driver output frequency to be set at any fixed point across the frequency range.

The single-turn variable potentiometer (PWR ADJ) situated to the left of the front panel LED's sets the maximum RF power level. This is level that will be achieved for the maximum Modulation input

**NOTE : Maximum power = fully clockwise**

### LED indicators

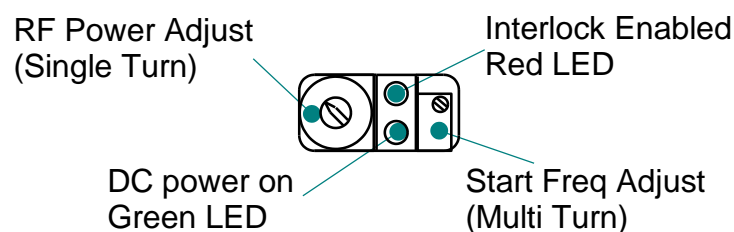

### DC supply

Filtered screw terminal connection.

A low impedance 24Vdc (or 28Vdc) DC power supply is required for operation of the RFA341. The required voltage is +24Vdc at a current drain of approximately 7.0A. The external power source should be regulated to  $\pm 2\%$  and the power supply ripple voltage should be less than 200mV for best results.

The driver will output higher RF power if operated from 28Vdc. See test data sheet.

**Water cooling is mandatory. The heatsink temperature must not exceed 70°C.**

**SERIOUS DAMAGE TO THE AMPLIFIER MAY RESULT IF THE TEMPERATURE EXCEEDS 70°C.  
SERIOUS DAMAGE TO THE AMPLIFIER MAY ALSO RESULT IF THE RF OUTPUT CONNECTOR IS OPERATED OPEN-CIRCUITED OR SHORT-CIRCUITED**

### 3. INSTALLATION AND ADJUSTMENT

(See Figures 4 & 5)

- 3.1 Connect cooling water at a flow rate greater than 1 litres/minute at < 25 deg.C  
(Push-fit water connections are provided to suit 6mm plastic tubing).
- 3.2 Connect the + 24Vdc supply. DO NOT APPLY POWER.
- 3.3 Connect the RF output BNC jack to the SMA or BNC RF input of the acousto-optic deflector  
(or a 50Ω RF load, if it is desired to measure the modulator RF output power).
- 3.4 Connect the amplitude control source to the the D-type connector.
- Connect the modulation signal ( 0,0 - 10V) to pin 8
  - Connect the signal return (0V) to pin 3
- To begin, apply a constant voltage of 5.0V.
- 3.5 Connect the external Interlock of the acousto-optic modulator (if fitted) to the enable inputs on the 9-pin D-type connector. If no interlock is fitted then these inputs MUST be connected together. (At 12V potential, < 2mA)
- Connect pin 9 to the floating contact 1 of the interlock switch.
  - Connect pin 4 to floating contact 2 of the interlock switch. (Grounded at driver)

The interlock connection becomes open circuit disabling the RF output, if the temperature of the modulator exceeds 30°C or the internal driver temperature exceeds 50°C. An LED indicator illuminates when the Interlocks are closed and the RF is enabled.

- 3.6. Connect the tuning voltage source to the the D-type connector
- Connect the tuning signal ( 0,0 -10.0V) to pin1
  - Connect the signal return (0V) to pin 6
- 3.6a Optional Digital Gate input
- If required apply a 12V CMOS compatible or open drain connection to the Digital Gate input
- Connect the tuning signal ( 12v tolerant) to pin 7
  - Connect the signal return (0V) to pin 2
- This input may be left NC (Not connected). A closed contact on this input will disable the RF Output. Response time 10msec

- 3.7 Adjustment of the RF output power is best done with amplifier connected to the acousto-optic modulator
- The optimum RF power level required for the modulator to produce maximum first order intensity will be different at various laser wavelengths. Applying RF power in excess of this optimum level will cause a decrease in first order intensity (a false indication of insufficient RF power ) and makes accurate Bragg alignment difficult. It is therefore recommended that initial alignment be performed at a low RF power level.*
- 3.8 Locate the PWR ADJ access on the driver end plate.
- 3.9 With an insulated alignment tool or screwdriver rotate the PWR ADJ potentiometer fully anti-clockwise (CCW) i.e.OFF, then clockwise (CW) approx 1/2 turn.
- 3.10 Apply + 24V DC to the amplifier. Turn on the Cooling water.
- 3.11 Apply a 10.0V constant modulation signal to the modulation input, pin 8 of the D-type connector.
- 3.12 Apply a 5.0V constant tuning voltage to the tuning input, pin 1 of the D-type connector. This will operate the deflector at its mid-scan position.
- 3.13 Align the deflector head to insure that the incident light beam is centred in the active aperture of the deflector. The following explanation assumes the light beam is directed slightly toward the transducer (connector end) of the deflector
- Observe the diffracted first-order output from the acousto-optic modulator and the undeflected zeroth order beam. Adjust the Bragg angle (rotate the deflector) to maximise first order beam intensity.
- 3.14 After Bragg angle has been optimized, slowly increase the RF power (rotate PWR ADJ CW) until maximum first order intensity is obtained. Record this intensity value ( $I_{SAT}$ ).
- 3.15 To equalise deflection efficiency across the extremes of the scan, alternate between the minimum and maximum desired frequencies (full range = 0.0V and 10.0V tuning voltage resp. ) and adjust the Bragg angle to give the same efficiency at both positions. Fine tuning of the incident Bragg angle and RF power may be necessary for optimum results.
- 3.16 The RFA341 is now ready for use as a variable frequency AO driver.



#### 4. MAINTENANCE

##### 4.1 Cleaning

It is of utmost importance that the optical apertures of the deflector optical head be kept clean and free of contamination. When the device is not in use, the apertures may be protected by a covering of masking tape. When in use, frequently clean the apertures with a pressurized jet of filtered, dry air.

It will probably be necessary in time to wipe the coated window surfaces of atmospherically deposited films. Although the coatings are hard and durable, care must be taken to avoid gouging of the surface and residue of the cleaning solution. It is suggested that the coatings be wiped with a soft ball of brushed (short fibres removed) cotton, slightly moistened with clean alcohol. Before the alcohol has had time to dry on the surface, wipe again with dry cotton in a smooth, continuous stroke. Examine the surface for residue and, if necessary, repeat the cleaning.

##### 4.2 Troubleshooting

No troubleshooting procedures are proposed other than a check of alignment and operating procedure. If difficulties arise, take note of the symptoms and contact the manufacturer.

##### 4.3 Repairs

In the event of deflector malfunction, discontinue operation and immediately contact the manufacturer or his representative. Due to the high sensitive of tuning procedures and the possible damage which may result, no user repairs are allowed. Evidence that an attempt has been made to open the optical head will void the manufacturer's warranty.

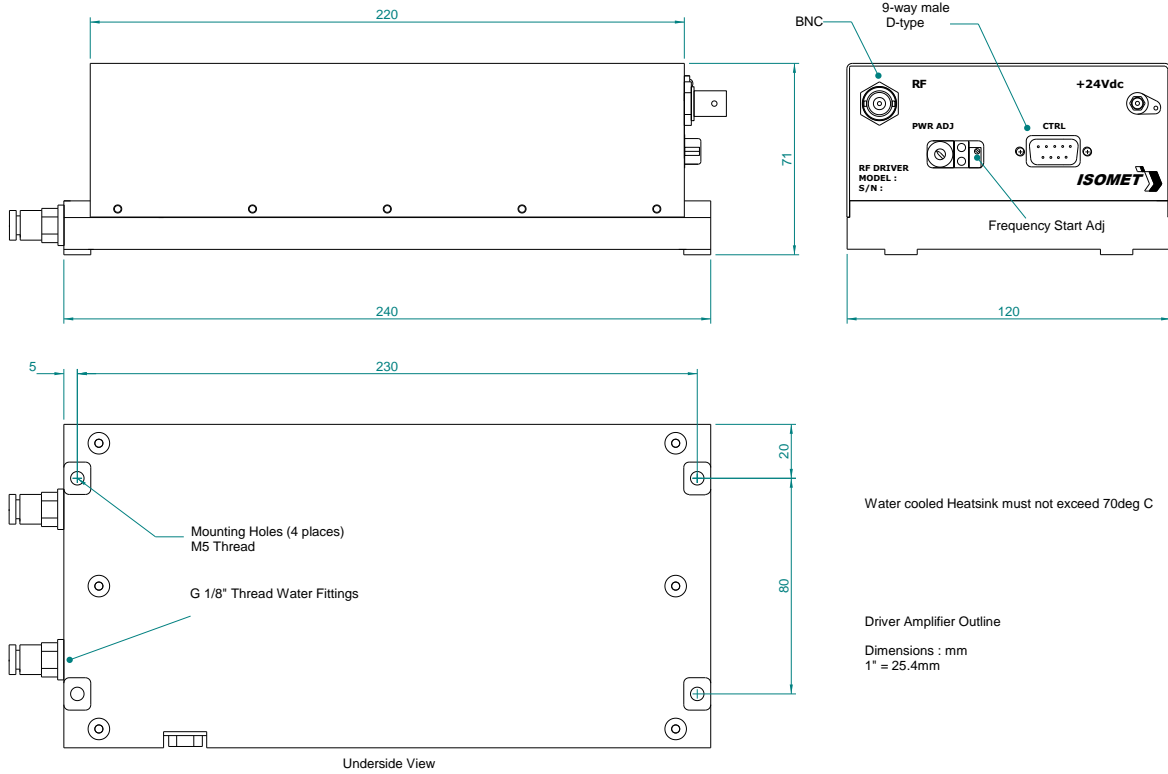

Control signals -	:	9 pin 'D' type
Tuning Voltage	:	+sig pn1, -rtn pn6
Amplitude Control	:	+sig pn8, -rtn pn3
Enable/Interlock Control (Low = On)	:	+sig pn9, -rtn pn4
Digital Gate Input (NC or High = On)	:	+sig pn7, -sig pn2

Not shown  
 Frequency monitor output, *Fmon* : SMA

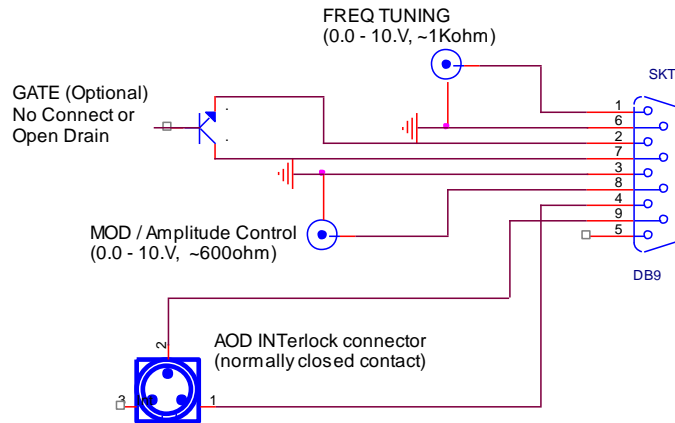

Fig 1: RFA341

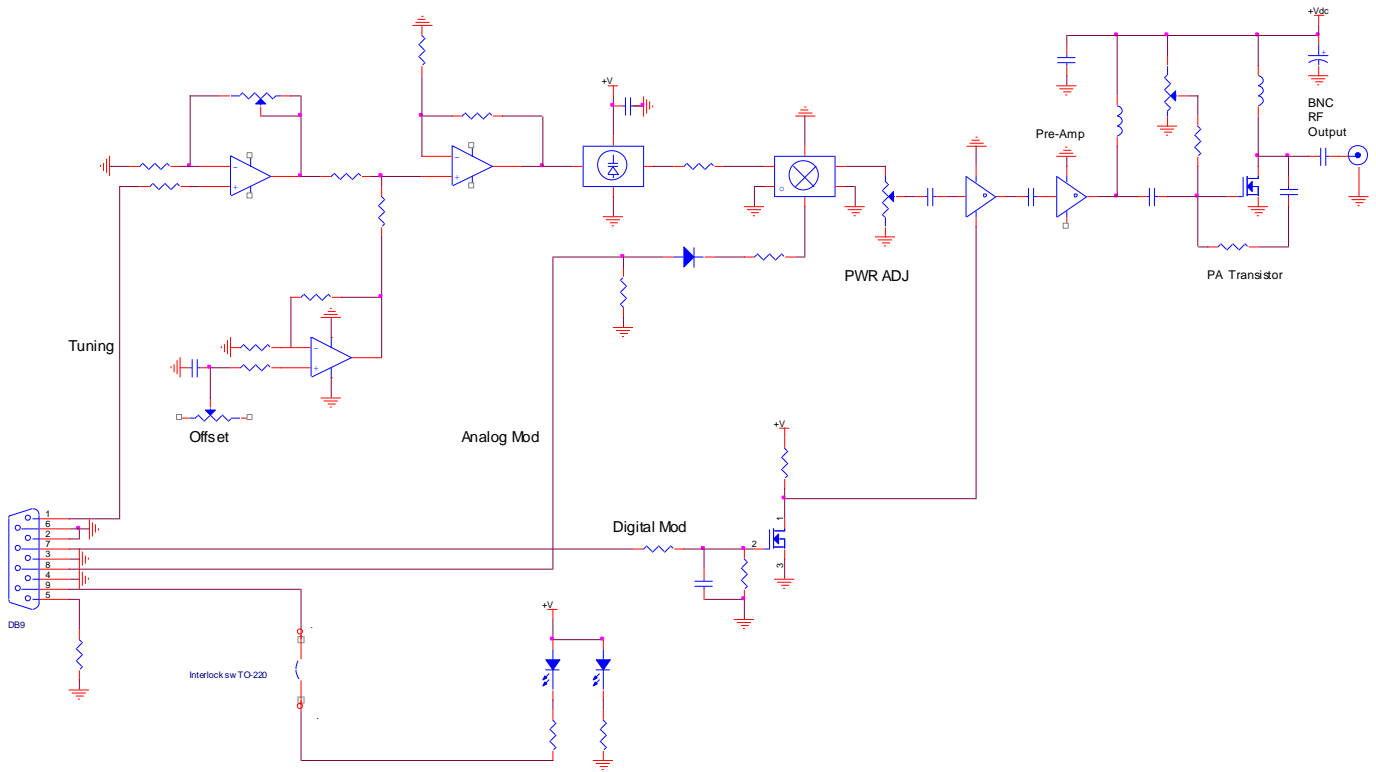
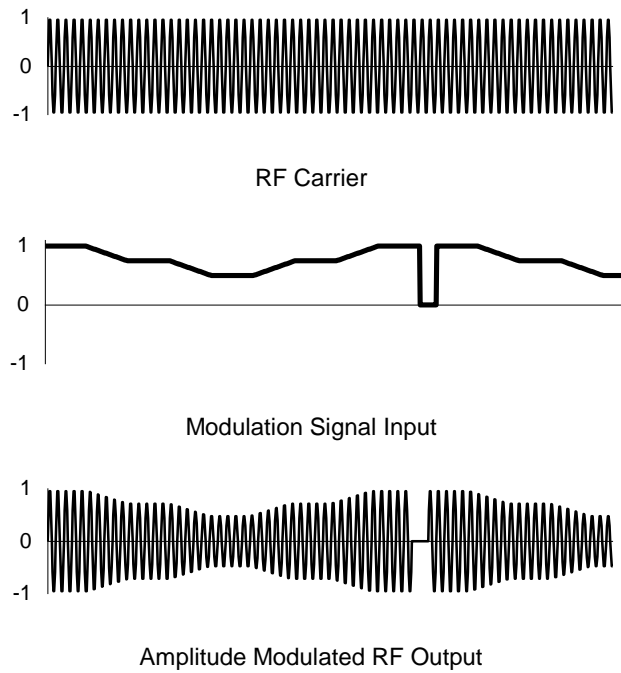

Figure 2: Driver Block Diagram for RFA341 driver/amplifier





Typical analog modulation RF waveforms are shown above. For the RFA341 and similar drivers, the modulation input is a combination of analog and digital enable/gate as illustrated below.

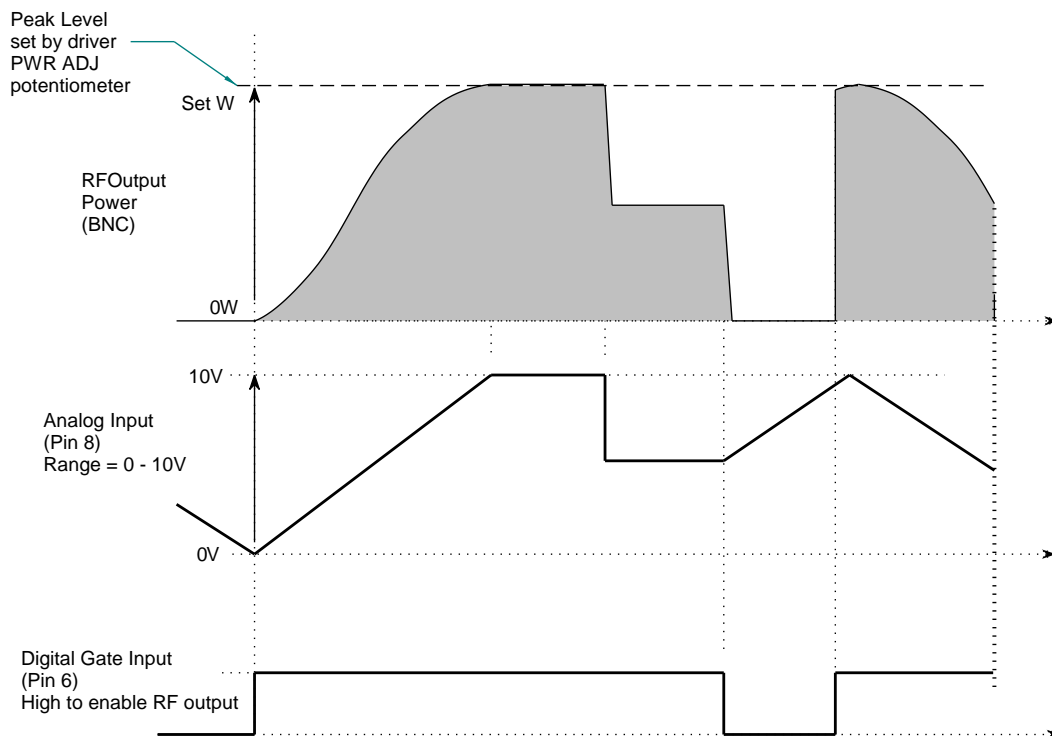
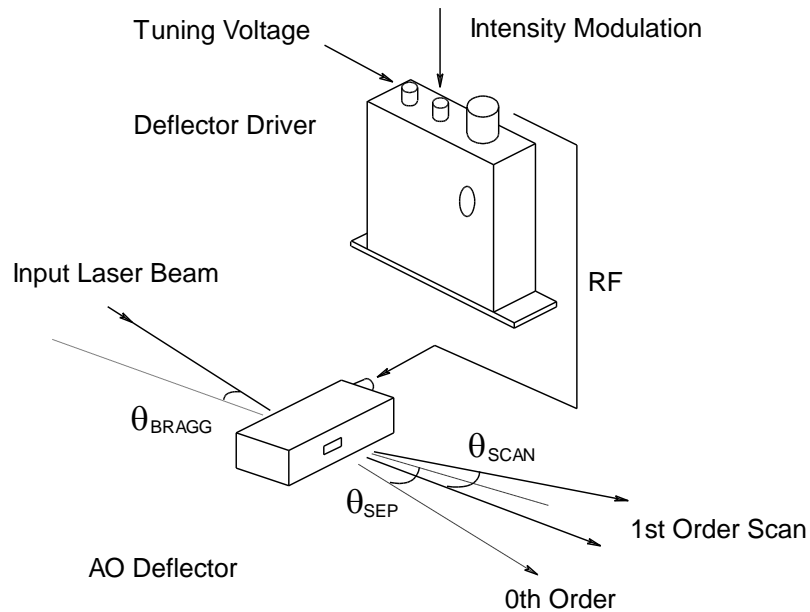

Figure 3: Typical Modulation Waveforms

**Schematic of a single electrode acousto optic deflector and tunable driver**



The input bragg angle, relative to a normal to the optical surface and in the plane of deflection is given by:

$$\theta_{BRAGG} = \frac{\lambda \cdot fc}{2 \cdot v}$$

The separation angle between the zeroth order and mid scan point of the first order is given by:

$$\theta_{SEP} = \frac{\lambda \cdot fc}{v}$$

The first order scan angle is given by:

$$\theta_{SCAN} = \frac{\lambda \cdot \delta f}{v}$$

The access time or time aperture is given by:

$$T_{acc} = \frac{d}{v}$$

- where :
- $\lambda$  = wavelength
  - $\delta f$  = scan frequency bandwidth
  - $fc$  = centre frequency
  - $v$  = acoustic velocity of the crystal material (Ge = 5.5mm/usec)
  - $d$  = beam diameter

Figure 4: Deflector Parameters

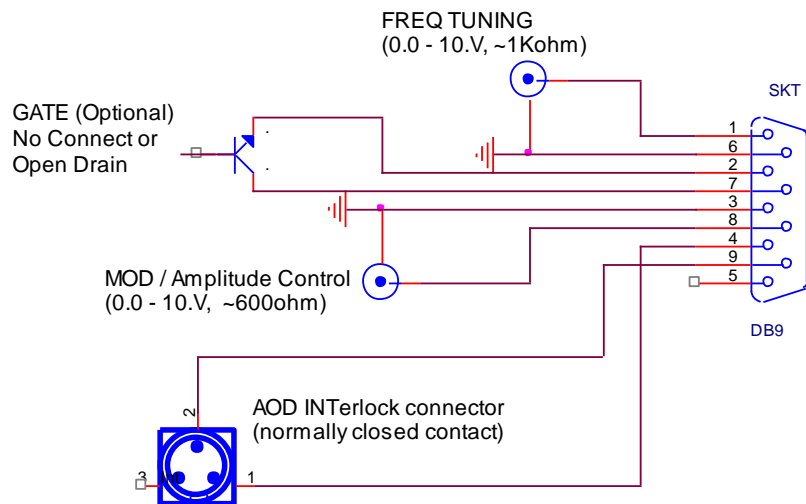
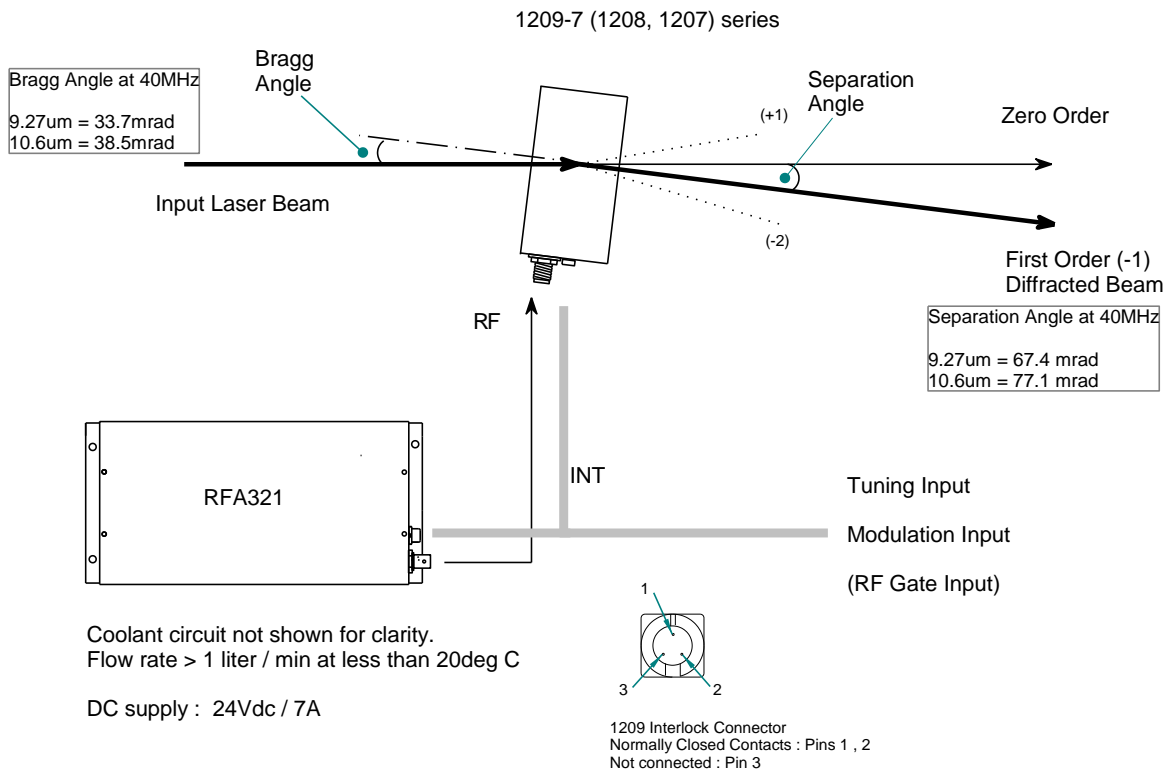
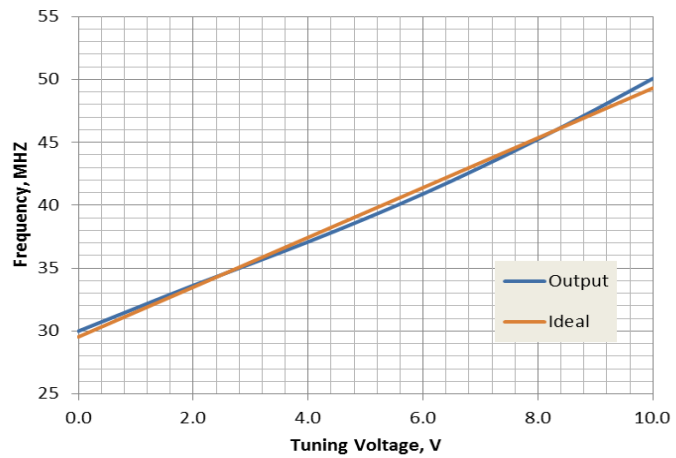

Figure 5: Connections and Typical orientation

Typical Tuning Characteristic



Typical Modulation Characteristic

500KHz at 60W / 40MHz RF

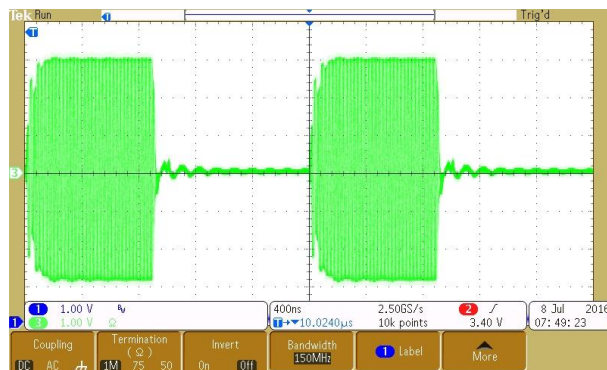

Typical RF Power vs. Frequency response (1dB/div)

30-50MHz sweep.

20W, 40W and 80W nominal RF power settings



Figure 6